

HIGH PERFORMANCE BOTTOM CARTON PULL

CARTON ERECTING SOLUTION



**BUILT FOR SIMPLE
CARTON CHANGEOVER
& HEAVY USAGE**

QUICK HIGHLIGHTS

SEALS UP TO 10 CARTONS PER/MIN.*

*SPEED DEPENDENT ON CARTON SIZE AND MACHINE OPTIONS

- Carton Straight Fed From The Hopper/Carton Bottom Pulled
- Manual Jog Button for Step-by-Step Activation
- Quick & Easy Manual Length, Width and Height Adjustments
- Hopper Holds 70-100 Cartons (Depending on Carton Size)



CARTON RANGE

Specifications based on ESHB11-2

Length (min. - max.) (6.0" - 25.5")	Width (min. - max.) (6.0" - 14.0")	Height (min. - max.) (6.5" - 20.0")
--	---	--

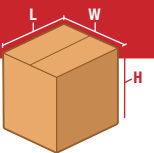

ESHB

AUTOMATIC STRAIGHT FEED CASE ERECTOR

Our BestPack™ Packaging ESHB is an innovative high performance carton erector/sealer using a bottom carton pull system in the hopper. The ESHB is designed for RSC cartons where both L x W have the same measurements (square cartons) and also standard rectangular cartons. The ESHB erector is built for heavy usage with quick and simple carton size change over. If you are looking for a simple yet heavy built carton erector, this is a must-see unit.



FREE PRODUCT SUPPORT:
TRAINING VIDEOS | ONLINE MANUALS | TECH SUPPORT

*CONTACT YOUR LOCAL BESTPACK REPRESENTATIVE FOR MORE INFORMATION

WWW.BESTPACK.COM

VERSION 5.1_0924



VENTURI SUCTION CUP SYSTEM

Ensures reliable attachment by amplifying air pressure for strong grip on cartons.



INTERLOCK SAFETY GATES

Providing safety and preventing workplace injury.



HEAVY DUTY FRAME

4x longer lasting than bolted frames.



LOW TAPE/ NO TAPE/ NO CUT SENSORS

Low tape, no tape and no cut monitoring system notifies the user of potential downtime.



HMI- HUMAN MACHINE INTERFACE

Operator controls panel that provides reliable data & troubleshooting at your fingertips.



CARTON ON DEMAND SENSORS

Included with your carton erector, preventing carton jamming & down time

MACHINE FOOTPRINT

Specifications based on ESHB11-2

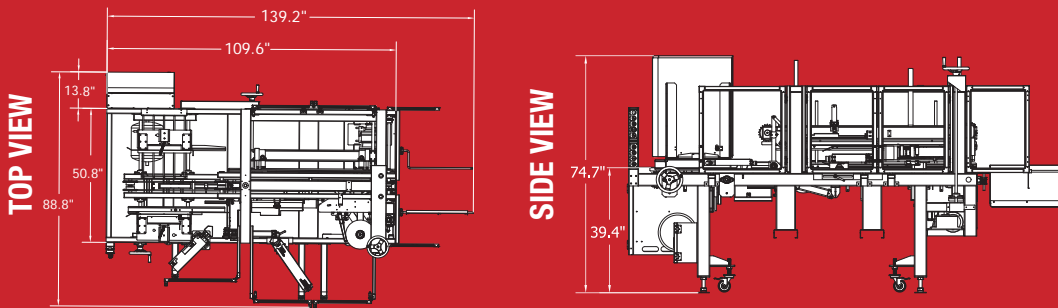

Note: Dimensions are all subject to change without prior notification.

OPTIONS

- Pre-Stacked Automatic Carton Infeed Conveyor
- Automatic Tape Head Center Seal Adjustment
- Available in Stainless Steel
- Exit Conveyor

POPULAR ESHB MODELS

PLEASE REFER TO COMPARISON CHART FOR COMPLETE LIST OF MODELS.

MODEL	MACHINE DIMENSIONS LENGTH x WIDTH x HEIGHT	CARTON RANGE* LENGTH (min. - max.) x WIDTH (min. - max.) x HEIGHT (min. - max.)	CONVEYOR HEIGHT HEIGHT (min. - max.)	CARTONS PER MIN.	SHIPPING WEIGHT (LBS)	POWER REQUIREMENTS	AIR REQUIREMENTS
ESHB11-2 2" Tape Head	(139.2") x (8.8") x (74.7")	(6.0" - 25.5") x (6.0" - 14.0") x (6.5" - 20.0")	(22.5" - 30.0")	Up to 10	2,425	110 Volts 60 Single Phase Current Hz	100 PSI, 10+ SCFM
ESHB11-3 3" Tape Head	(139.2") x (8.8") x (74.7")	(6.0" - 25.5") x (6.0" - 14.0") x (6.5" - 20.0")	(22.5" - 30.0")	Up to 10	2,425	110 Volts 60 Single Phase Current Hz	100 PSI, 10+ SCFM

INFORMATION SUBJECT TO CHANGE WITHOUT NOTICE.

*OUTSIDE DIMENSIONS ONLY



For more information please go to:
WWW.BESTPACK.COM or call us at **1.888.588.2378**