

1-EDGE

MANUAL SIDEDRIVE

CARTON SEALING SOLUTION

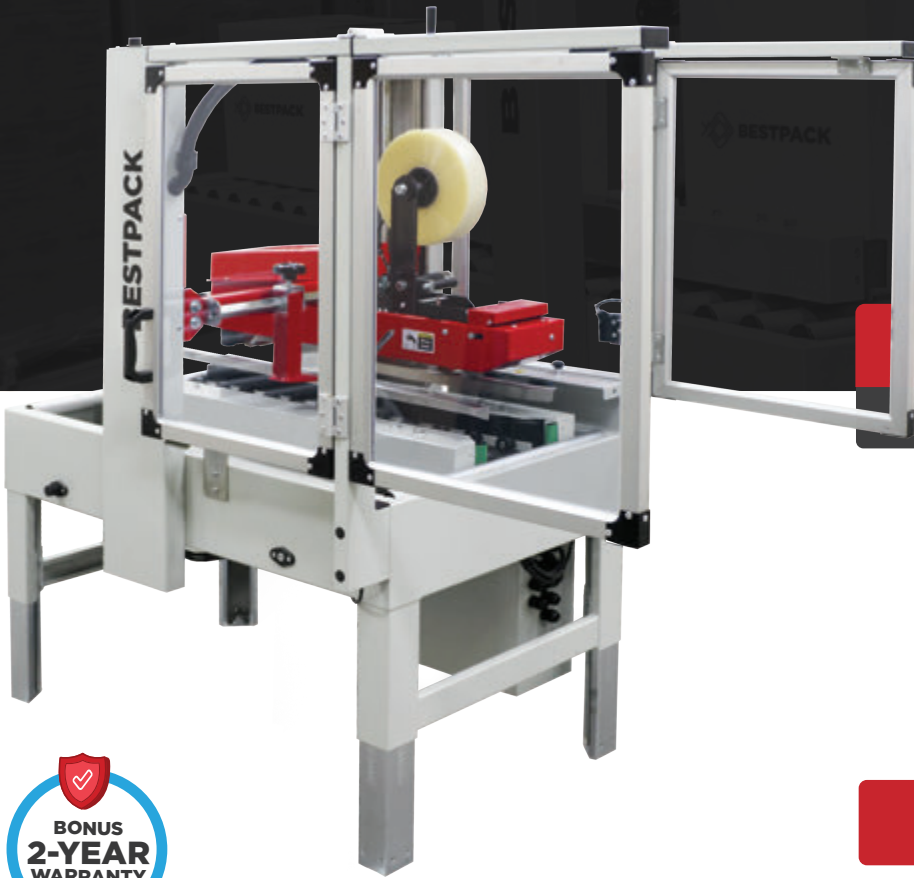

**PERFECT SOLUTION FOR
SUBSCRIPTION BOX
INDUSTRY**

QUICK HIGHLIGHTS

SEALS UP TO 45 CARTONS PER/MIN.*

*SPEED DEPENDENT ON CARTON SIZE AND MACHINE OPTIONS

- Designed Specifically to Seal Clamshell Cartons
- Ability to Swap Between Single or Multi-Tab Edge Sealing
- Can be Converted to an Operator Free Solution with Adjustable Indexer
- Maintenance Free Air Cylinders

CARTON RANGE

Specifications based on MS1ETR22-2

Length
(min. - max.)
(7.0" - U)

Width
(min. - max.)
(1.72" - 5.5")

Height
(min. - max.)
(4.0" - 21.75")

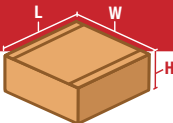

MS1E MANUAL SIDEDRIVE 1-EDGE CARTON SEALER

The BestPack™ MS1E Series is a 1-edge high-speed semi-automatic uniform carton sealer using pressure sensitive tape. The MS1E is available in either 1-edge top left or 1-edge top right. This 1-edge sealer is an operator fed adjustable sealer that can also be converted to an operator free adjustable 1-edge sealer with the addition of a matching adjustable indexer. Depending on the motor drive speed used the MS1E can reach carton speeds of over 45 cartons per minute. This sealer excels at one edge sealing clamshell, flap tuck and flap edge lock type cartons both in corrugated and chipboard.



FREE PRODUCT SUPPORT:
TRAINING VIDEOS | ONLINE MANUALS | TECH SUPPORT

*CONTACT YOUR LOCAL BESTPACK REPRESENTATIVE FOR MORE INFORMATION

WWW.BESTPACK.COM

VERSION 2.0_0124



VERSATILE 1-EDGE SEAL (TOP LEFT OF RIGHT SEAL)
Utilizing pressure-sensitive tape for a single tape seal on clamshell cartons.



FRONT INTERLOCK SAFETY GATES
Providing safety and preventing workplace injury.



SIDE BELT DRIVE
Gently pulls product through while reducing less wear & tear on parts.



CNC CUT AND WELDED FRAME
4x longer lasting than bolted frames.



PNEUMATIC TAPE EDGE WIPER
Provides a clean and consistent edge seal on clamshell cartons.



ACCESSIBLE TECHNICAL SUPPORT
Convenient technical support is readily available via a QR code on solution.

MACHINE FOOTPRINT

Specifications based on MS1ETR22-2

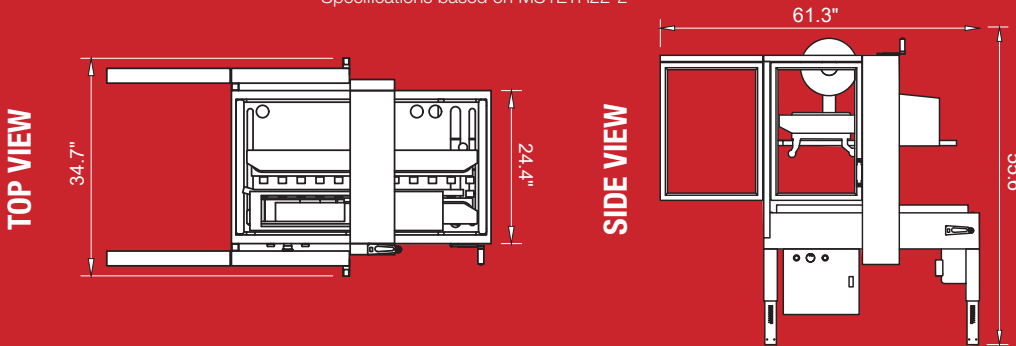

Note: Dimensions are all subject to change without prior notification.

OPTIONS

- High-Speed Motor Upgrade (up to 125 ft. per min)
- Indexer
- Infeed/Exit Conveyor w/L-Bracket Stabilizer
- Heavy Duty Locking Casters
- Low Tape/No Tape Monitoring

POPULAR MT1E MODELS

PLEASE REFER TO COMPARISON CHART FOR COMPLETE LIST OF MODELS.

MODEL	MACHINE DIMENSIONS LENGTH x WIDTH x HEIGHT	CARTON RANGE LENGTH (min. - max.) x WIDTH (min. - max.) x HEIGHT (min. - max.)	CONVEYOR HEIGHT HEIGHT (min. - max.)	CARTONS PER MIN.	SHIPPING WEIGHT (LBS)	POWER REQUIREMENTS	AIR REQUIREMENTS
MS1ETL22-2 2" Tape Head Top Left Edge	(61.3") x (34.7") x (55.6" - 68.75")	(7.0" - U) x (1.72" - 5.5") x (4.0" - 21.75")	(23.5" - 30.0")	Up to 45	350	110 Volts 60 Hz 1.9 A, 122 watts/motor Power Requirements	50 PSI, 5 SCFM
MS1ETR22-2 3" Tape Head Top Right Edge	(61.3") x (34.7") x (55.6" - 68.75")	(7.0" - U) x (1.72" - 5.5") x (4.0" - 21.75")	(23.5" - 30.0")	Up to 45	350	110 Volts 60 Hz 1.9 A, 122 watts/motor Power Requirements	50 PSI, 5 SCFM

INFORMATION SUBJECT TO CHANGE WITHOUT NOTICE.

ALL MODELS AVAILABLE IN HIGH SPEED & FOOD GRADE 304 STAINLESS STEEL



For more information please go to:
WWW.BESTPACK.COM or call us at **1.888.588.2378**

© 2024 BestPack Packaging Systems. All rights reserved. This document is BestPack Public Information.