



BESTPACK

RANDOM LOW PROFILE LOW PROFILE

CARTON SEALING SOLUTION



**SEALS
CARTONS**

AS LOW AS 2.5" IN HEIGHT

QUICK HIGHLIGHTS

SEALS UP TO 12 CARTONS PER/MIN.*

*SPEED DEPENDENT ON CARTON SIZE AND MACHINE OPTIONS

- “Soft Touch” Pneumatic System is Gentle on Cartons
- Low Profile Top & Bottom Seal
- Dual Telescoping Masts
- Seals Random Size Cartons Without Stopping for Adjusting
- Maintenance Free Air Cylinders

CARTON RANGE

Specifications based on RSL22-2

Length
(min.-max.)
(6.0"-U")

Width
(min.-max.)
(5.7"-21.0")

Height
(min.-max.)
(2.5"-20.5")

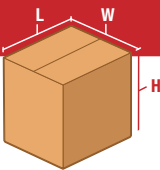

RSL RANDOM SIDEDRIVE LOW PROFILE CARTON SEALER

The BestPack™ RSL Series is a Semi-Automatic Random Tape Carton Sealers designed to seal very low profile cartons in addition to the wide range expected of a random carton sealer. Build for speed and durability, the RSL’s low profile feature allows for the effective sealing of cartons at a minimum height of 2.5". The RSL is capable of sealing cartons up to 20.5" tall as well.



FREE PRODUCT SUPPORT:
TRAINING VIDEOS | ONLINE MANUALS | TECH SUPPORT

*CONTACT YOUR LOCAL BESTPACK REPRESENTATIVE FOR MORE INFORMATION
WWW.BESTPACK.COM

VERSION 5.1_0225



“SOFT TOUCH” PNEUMATIC SYSTEM

Air powered belt drive and sealing section decreases product damage while maintaining presentation.



SIDE BELT DRIVE SYSTEM

Gently pulls product through while reducing less wear & tear on parts.



COMPLETE BED ROLLER SYSTEM

Increase through put while reducing strain on the motor.

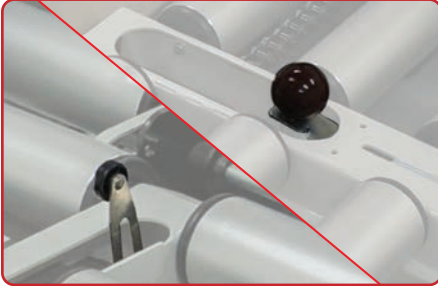

INFEED AND EXIT LIMIT SWITCHES

Starts and resets upon activation, decreases energy consumption and risk of injury.



OFFSET TAPE HEADS

Enables precise and efficient sealing of low-profile cartons, individually sealing top and bottom of carton.



ACCESSIBLE TECHNICAL SUPPORT

Convenient technical support is readily available via a QR code on solution.

MACHINE FOOTPRINT

Specifications based on RSL22-2

TOP VIEW

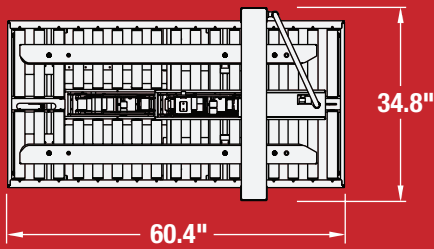

SIDE VIEW

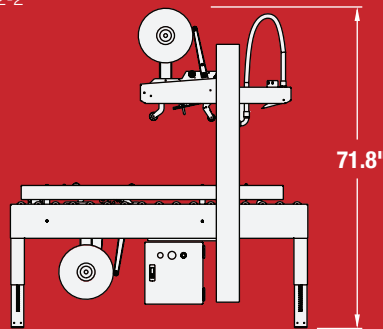

Note: Dimensions are all subject to change without prior notification.

OPTIONS

- High-Speed Motor Upgrade (Up to 125 ft. per min)
- Heavy Duty Locking Casters
- Infeed/Exit Conveyors w/L-Bracket Stabilizer
- Interlock Safety Gates
- Available in Stainless Steel

POPULAR RSL MODELS

PLEASE REFER TO COMPARISON CHART FOR COMPLETE LIST OF MODELS.

MODEL	MACHINE DIMENSIONS LENGTH x WIDTH x HEIGHT	CARTON RANGE* LENGTH (min. - max.) x WIDTH (min. - max.) x HEIGHT (min. - max.)	CONVEYOR HEIGHT HEIGHT (min. - max.)	CARTONS PER MIN.	SHIPPING WEIGHT (LBS)	POWER REQUIREMENTS	AIR REQUIREMENTS
RSL22-2 2" Tape Head	(60.4") x (34.8") x (71.8")	(6.0" - U) x (5.7" - 21.0") x (2.5" - 20.5")	(20.5" - 30.0")	Up to 12	450	110 Volts 60 Hz	55-60 PSI, 5 SCFM
RSL22-3 3" Tape Head	(60.4") x (34.8") x (71.8")	(6.0" - U) x (6.7" - 21.0") x (2.5" - 20.5")	(20.5" - 30.0")	Up to 12	450	110 Volts 60 Hz	55-60 PSI, 5 SCFM
RSL22-2NC 2" Tape Head	(60.4") x (34.8") x (71.8")	(6.0" - U) x (5.7" - 21.0") x (2.5" - 20.5")	(20.5" - 30.0")	Up to 12	450	110 Volts 60 Hz	55-60 PSI, 5 SCFM
RSL22-3NC 3" Tape Head	(60.4") x (34.8") x (71.8")	(6.0" - U) x (5.7" - 21.0") x (2.5" - 20.5")	(20.5" - 30.0")	Up to 12	450	110 Volts 60 Hz	55-60 PSI, 5 SCFM

INFORMATION SUBJECT TO CHANGE WITHOUT NOTICE. *OUTSIDE DIMENSIONS ONLY | U - UNLIMITED | ALL MODELS AVAILABLE IN HIGH SPEED & FOOD GRADE 304 STAINLESS STEEL



For more information please go to:
WWW.BESTPACK.COM or call us at **1.888.588.2378**

© 2025 BestPack Packaging Systems. All rights reserved. This document is BestPack Public Information.